

Eagle Workbook Appendices: Tyler Lee

PROPOSAL

Appendix A	Google Maps Picture of School	2
Appendix B	Google Maps Picture of Work Site	3
Appendix C	Google Maps Picture of Work Site	4
Appendix D	Sketches of Art Display (Front)	5
Appendix E	Sketches of Art Display (Back)	6
Appendix F	Safety Issues	7
Appendix G	List of Hopeful Donors	8 - 9
Appendix H	District Comments	10
Appendix I	Eagle Coach Comments	11

FINAL PLAN

Appendix J	Map to Nearest Hospital	12
Appendix K	Directions to Nearest Hospital	13 - 14
Appendix L	Home Depot Cost Analysis	15 - 17
Appendix M	Lowes Cost Analysis	18 - 20
Appendix N	Midway Supplies Cost Analysis	21 - 22
Appendix O	Joan Fabrics Cost Analysis	23
Appendix P	Car Wash Email Blast	24
Appendix Q	Car Wash Hour Log	25
Appendix R	Donation Letter	26
Appendix S	Donation Log	27
Appendix T	Work Processes	28 - 34
Appendix U	Art Display Hour Log	35
Appendix V	Personal Hour Log	36 - 38
Appendix W	Final Autodesk Renderings	39 - 40

PROJECT REPORT

Appendix X	Art Display Photos	41 - 42
Appendix Y	Check to Beneficiary	43

Appendix A (Google Maps Picture of School)

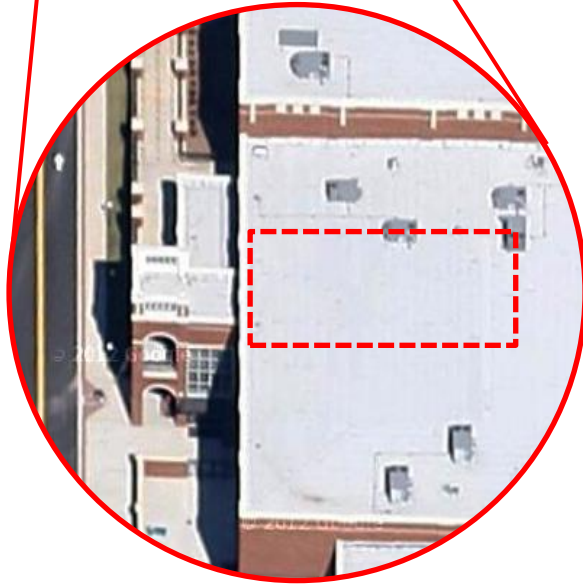
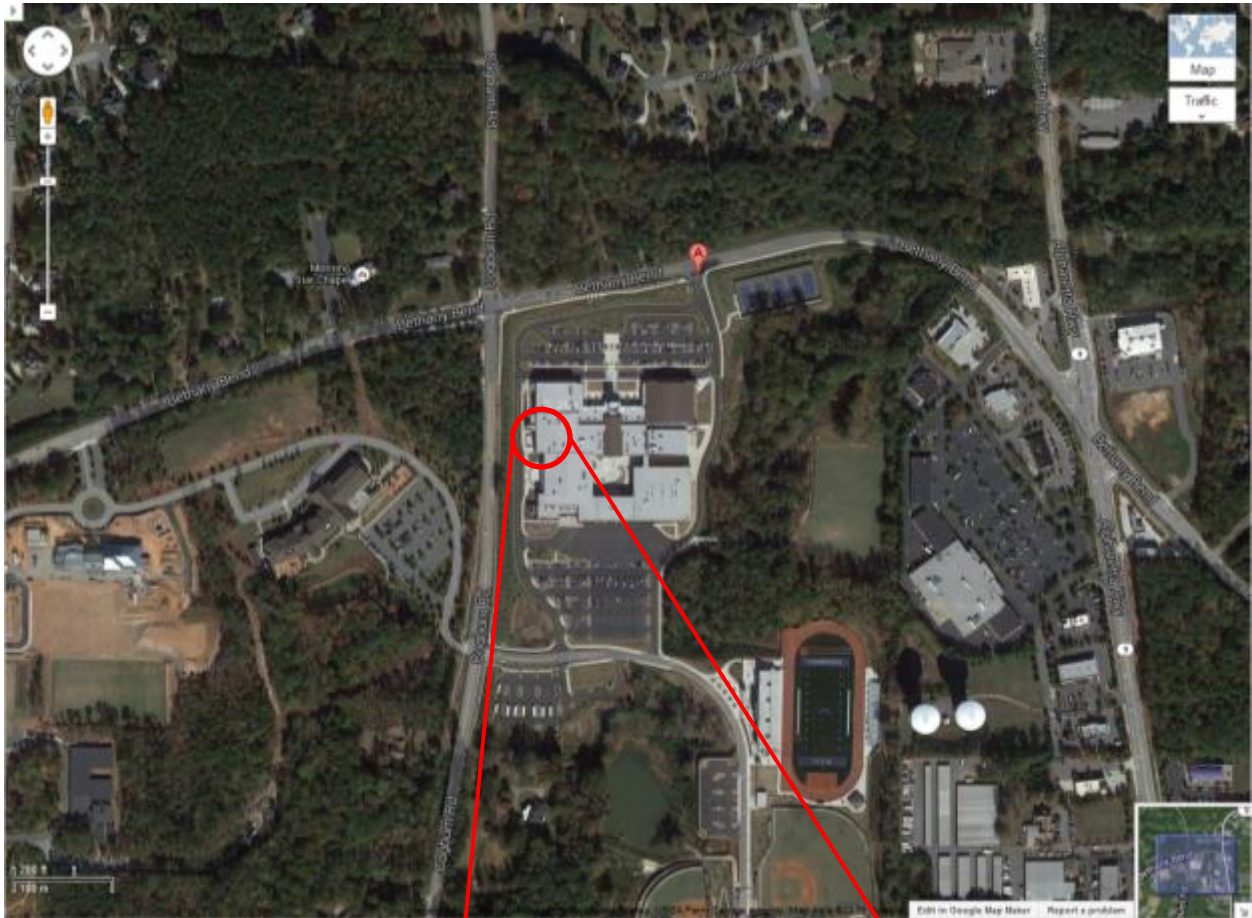

Appendix B (Google Maps Picture of Work Site)



Appendix C (Google Maps Picture of Work Site)



Appendix D (Sketches of Art Display)

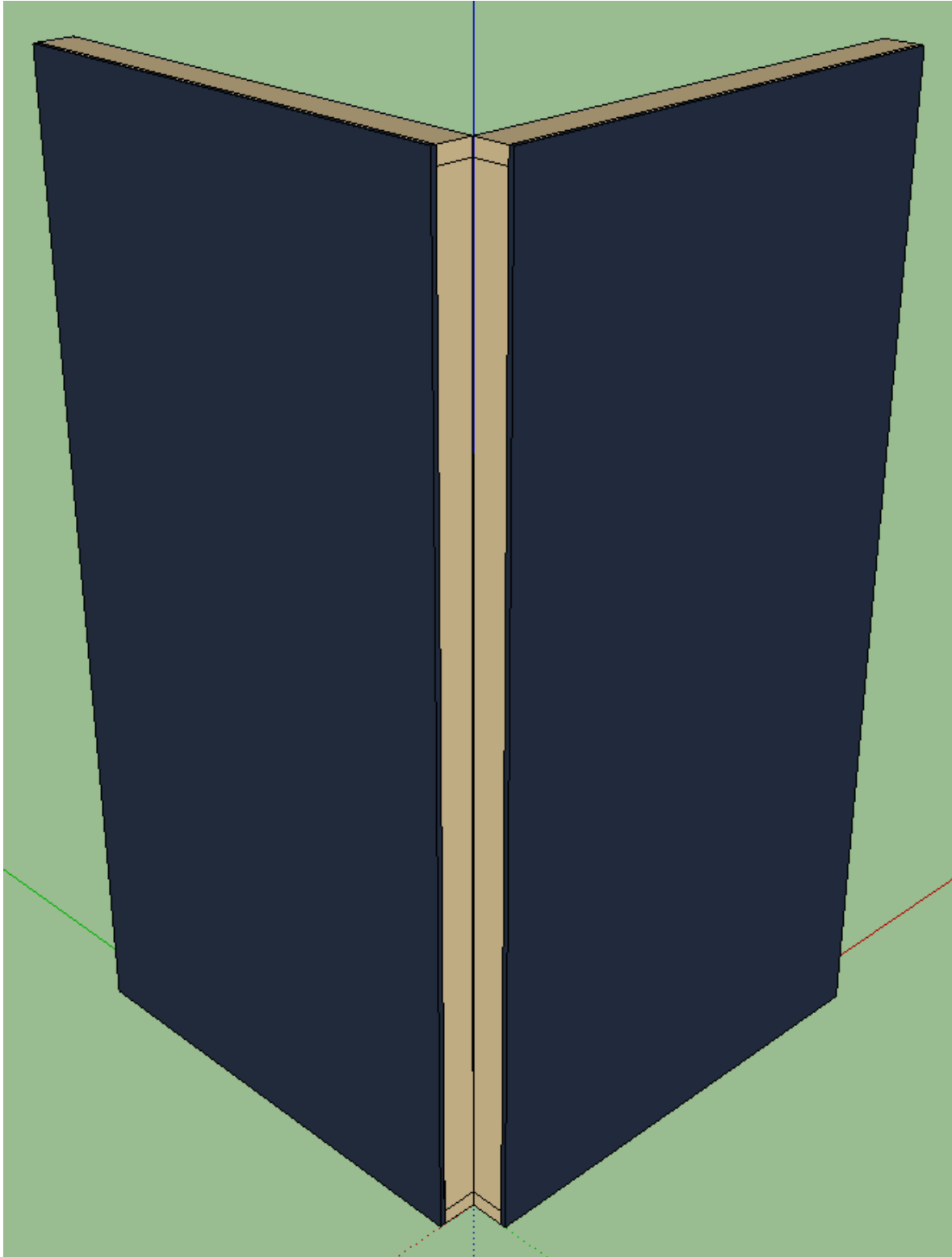

Appendix E (Sketches of Art Display)

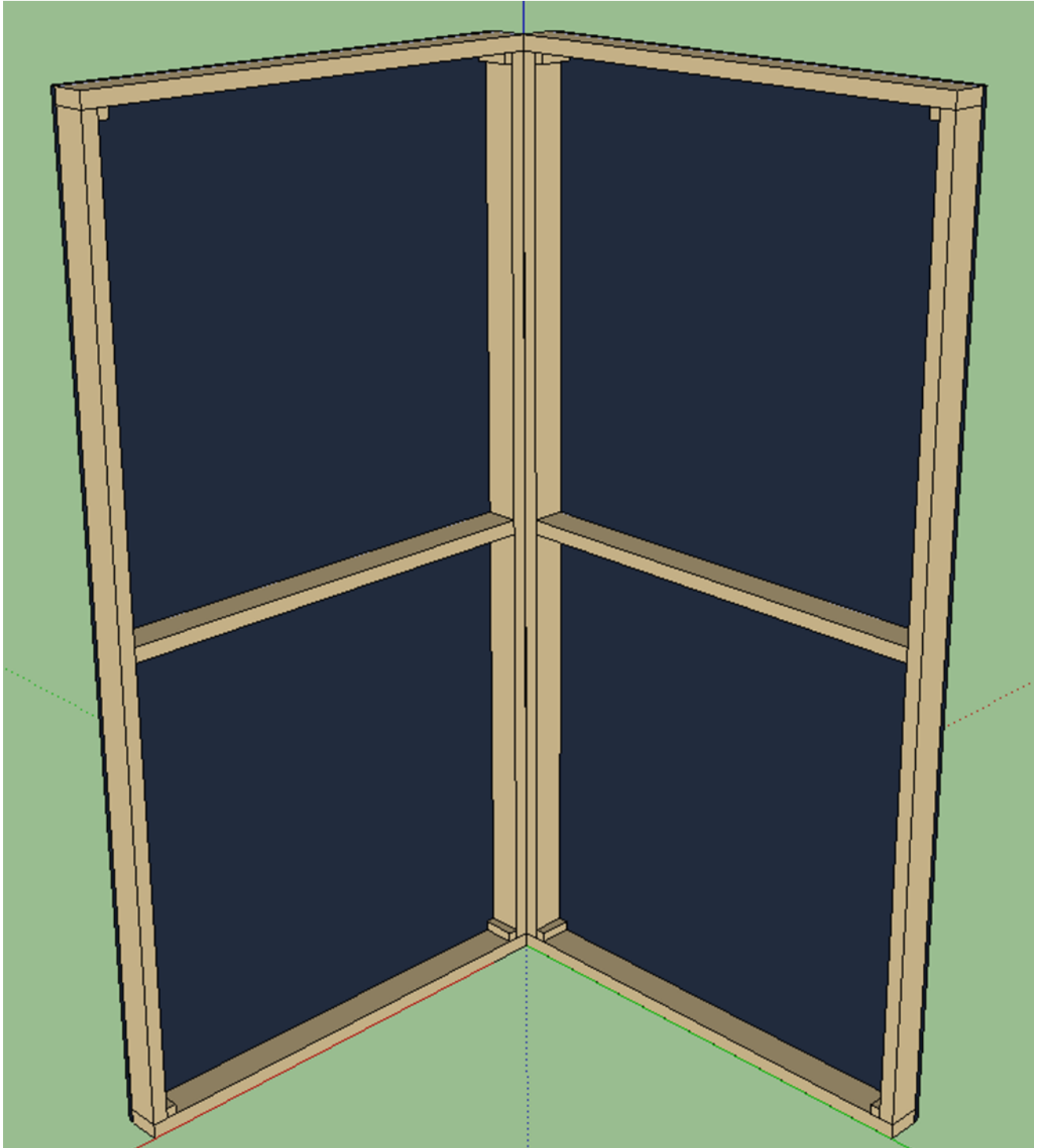

Appendix F (Safety Issues)

- Safety cutting wood – distracted cutter, wood chips to the eyes, cut fingers/hands
- Safety in operating power tools – distracted operator, slivers to the eyes, cut fingers/hands
- Safety in operating manual tools – distracted operator, slivers to the eyes, cut fingers/hands
- Traffic control – volunteers being harmed by a moving vehicle
- Location of closest hospital – emergency maps
- Hazards to the eyes – objects flying into the eye and causing eye damage
- Hazards to the hands – cuts to the hands, splinters to the hands
- Hazards to the feet – toe injury due to falling object or stubbing
- Hazards going to strangers homes – abuses, kidnapping, or worse
- Hazards of meeting strangers alone in a store worksite – abuses ,kidnapping, or worse
- Hazards from dehydration, hazards from sun or heat, insects, poison ivy
- Add statement about age appropriateness for use of power tools if being used

Appendix G (List of Hopeful Donors)

- Brian Lee
- Lynna Lee
- Rachel Lee
- Lauren Lee
- Michael Knapp
- Jennifer Knapp
- Robert Lee Sr.
- Doris Lee
- Andrew Lee
- Robert Lee Jr.
- Justin Lee
- Shelli Knapp
- Andrea Lee
- Mike
- Allison Streiff
- Cayce Jett
- Patti Hair
- John Hair
- Beverly Lee
- Sandra Lee
- Ron Lee
- Carole Ann Martinez
- Ricky Martinez
- Sebastian Blanc
- Vanessa Blanc
- Don Knapp
- Joe Iannarino
- Donnie Knapp
- Max Ovet
- Sam Ovet
- John Ames
- Steve Tipton
- John Monson
- Chris Dietel
- Pat Dennis
- Brian Manning

- Matt Brown
- Brandon Sloan
- Sean Lu
- Tony Lair
- Carey Lair
- Roberta Reed
- Paul Lascik
- Louise Lascik
- Linda Radman
- Bob Wince
- Georgia Vaughn
- Mildred Mulligan
- Matt Barnabei
- Janie Barnabei
- Brian Bristow
- Todd Neven
- Tomas Videla
- Pola Blackburn
- Majorie Gibson
- Bill Behlke
- Dina Behlke
- Alan Darnell
- Angie Darnell
- David Cox
- Julie Bailey
- Steve Best
- Bill Bond
- Becky Bond
- Mike Cunningham
- Sharron Cunningham
- Jeff Fester
- Gary Heit
- Carmelina DeSousa
- Dirk Herens
- Cobi Herens
- Susan Herget
- Mark Shuler
- Lisa Broadwell

Appendix H (District Comments)

- All donations will be recorded on a Donation Log and all surplus funds will be given to the Beneficiary
- Have maps and directions to the nearest hospital
- Keep a Log of Volunteer Hours
- Use the Patrol Method in your leadership plan
- Follow the Guide to Safe Scouting and the Guide to Age Appropriate tools for your entire project
- Try to include before and after pictures in your Final write up (no progress pictures please)

Appendix I (Eagle Coach Comments)

- Add district comments
- Coach comments
- Copy of each email blast and email for donations
- Donation log
- Volunteer sign in sheets
- Copy of check written to beneficiary

Appendix J (Map to Nearest Hospital)

North Fulton Regional Hospital

3000 Hospital Blvd.

Roswell, GA 30076

770-751-2500

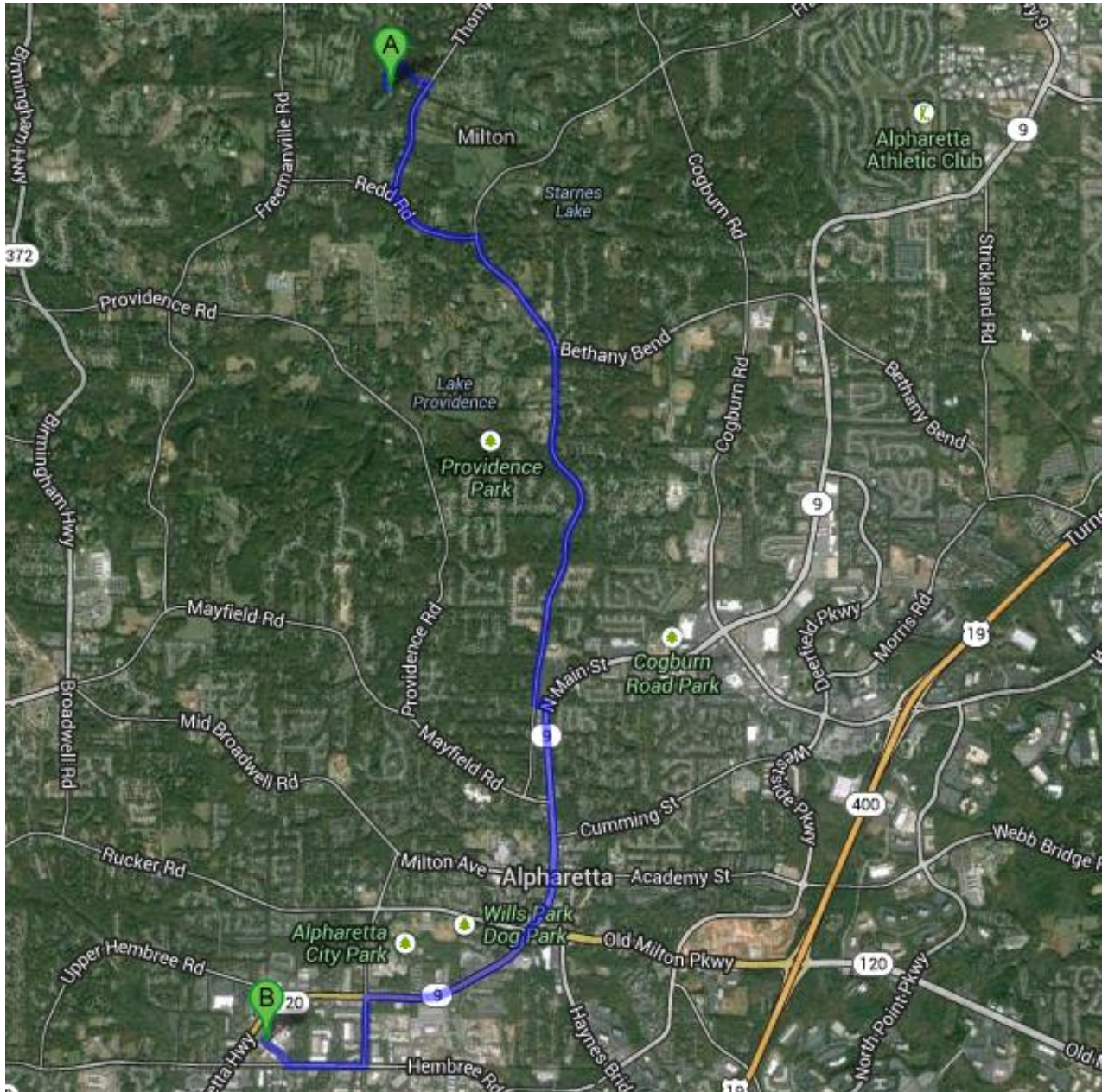

Appendix K (Directions to Nearest Hospital)

1. Head northwest on N Christophers Run toward Thompson Rd

About 1 min

Go 0.4 mi

Total 0.4 mi

2. Turn right onto Thompson Rd

About 1 min

Go 0.6 mi

Total 1.0 mi

3. Turn left onto Redd Rd

About 59 seconds

Go 0.5 mi

Total 1.6 mi

Show: [Text only](#) | [Map](#) | [Street View](#)

4. Turn right onto Hopewell Rd

About 4 minutes

Go 2.7 mi

Total 4.3 mi

5. Turn left onto Canton St

Go 397 feet

Total 4.4 mi

6. Turn right onto N Main St

About 4 minutes

Go 2.2 mi

Total 6.6 mi

7. Turn left onto Wills Rd

Go 0.4 mi

Total 7.0 mi

8. Turn right onto Hembree Rd

Go 0.4 mi

Total 7.4 mi

9. Turn right onto Hospital Blvd

Destination will be on the right

Go 0.2 mi

Total 7.6 mi

Appendix L (Home Depot Cost Analysis)

Item	Description	Dimensions	Quantity	Item #
Studs	16 Foot Whitewood 2 x 4	16' x 1.5" x 3.5"	35	161683
OSB Panel	Moisture-Resistant Plywood	4' x 8' x 7/32"	20	492930
Insulation Foam	Foam Board Insulation Panel	4' x 8' x 1/2"	20	1S01
Hinges	12 Pack of Door Hinges	3 1/2"	3	807374
Screws	Box of Drywall Screws	2 1/2"	1	633496

Item	Description	Cost	Quantity	Total Cost
Studs	16 Foot Whitewood 2 x 4	\$7.89	35	\$276.15
OSB Panel	Moisture-Resistant Plywood	\$12.47	20	\$249.40
Insulation Foam	Foam Board Insulation Panel	\$9.95	20	\$199.00
Hinges	12 Pack of Door hinges	\$22.98	3	\$68.94
Screws	Box of Drywall Screws	\$23.91	1	\$23.91

Total Cost of Supplies from Home Depot	Total Cost of Supplies with Tax from Home Depot
\$817.40	\$874.62

WILL-CALL (CUSTOMER PICK-UP)

Store: 0149 ALPHARETTA
 Will-Call: 261236W07
 Customer: LEE, BRIAN
 Address: 110 N CHRISTOPHERS RUN, MILTON, GA 30004

HOME DEPOT, INC.
 WILL CALL PICK LIST
 Pickup Date: 10/25/2014 - Pickup Time: 06:00 pm

SAT. >

Page 1 of 0
 As of: 10/25/2014
 Salesperson: 0075MN

Dept	SKU	Description	UPC	Vendor Name	Vendor Model	Retail	UM	To Pick	Picked	Location
21	0000-386-081	7/16" 4"X11" OSB	Multiple	NORBORD INDUSTRIES	386081	\$7.35	EA	16.00	16	
21	0000-181-640	2X4-95" PREMIUM KD WHITEWOOD STUD	Multiple	BOISE CASCADE BMDG	0207804	\$3.05	EA	64.00	64	
22	1000-014-420	1/2"X4"X8" POLY ISO ENERGY GUARD	0 73690 41436 6	DAP POLY ISO WALL SHEATH	1501	\$9.95	EA	16.00	16	
24	0000-421-791	1IN HEAVY DUTY 10 OZ	Multiple	MACCO ADHESIVES	1N-901	\$2.52	EA	12.00	12	REGISTER
25	0000-757-451	1-5/8" COARSE DRYWALL SCREW 5 LB	Multiple	PRIVESOURCE	158CDW55	\$21.97	EA	1.00	1	+3
25	0000-807-374	3.5" HINGE 5/8 RADIUS DRB 12PK	0 30689 13684 1	CROWN BOLT LLC	13884	\$22.98	PK	2.00	2	✓

Picked by: _____ Date/Time: _____

*** End of data for will-call *** Retail on regular merchandise is today's retail ***

Reprint this pick list after: Date: 10/25/2014 Time: 14:00:07
 *** End of data for report ***



Appendix M (Lowes Cost Analysis)

Item	Description	Dimensions	Quantity	Item #
Studs	8 Foot Whitewood 2 x 4	8' x 1.5" x 3.5"	70	6005
OSB Panel	Utility OSB Panel	4' x 8' x 1/4"	20	12206
Insulation Foam	Foam Board Insulation Panel	4' x 8' x 1/2"	20	15380
Hinges	12 Pack of Door Hinges	3 1/2"	3	503428
Screws	Box of Drywall Screws	2 1/2"	1	112628

Item	Description	Cost	Quantity	Total Cost
Studs	8 Foot Whitewood 2 x 4	\$3.05	70	\$213.50
OSB Panel	Utility OSB Panel	\$7.55	20	\$151.00
Insulation Foam	Foam Board Insulation Panel	\$9.48	20	\$189.60
Hinges	12 Pack of Door hinges	\$21.98	3	\$65.94
Screws	Box of Drywall Screws	\$21.97	1	\$21.97

Total Cost of Supplies from Lowes	Total Cost of Supplies with Tax from Lowes
\$642.01	\$686.95

Everyday
Low
Price
Utility Panel
4 x 8
Item # 12206 Model # 776391100000
0073291002001

\$9.48 Per Piece
1/2X4X8 IMP SHEATH R-1.3
Item # 15380
004178006353

\$21.98 BUY LOC
B 93
Item # 503428
Model # 3841-502
0886790011543
GH 12-CT 3-1/2IN 5/8IN ORB HINGE
CONTRACT BUYING

\$21.97 Everyday
Low
Price
DRYWLL SCRW CRSE 2 1/2 IN 5#
* Drywall or General Purpose
Item # 112628 Model # 1000000000
2 K 129

Appendix N (Midway Supplies Cost Analysis)

Item	Description	Dimensions	Quantity	Item #
Stud	#2 Spruce 2 x 4	8' x 1.5" x 3.5"	64	248S
OSB Panel	OSB Wafer Board 4 x 8	4' x 8' x 7/16"	16	12WAF
Liquid Nails	10 oz Tube	10 oz	24	LNS
Screws	Box of Drywall Screws	2 1/2"	1	5158DS

Item	Description	Cost	Quantity	Total Cost
Studs	#2 Spruce 2 x 4	\$3.23	64	\$206.72
OSB Panel	OSB Wafer Board 4 x 8	\$6.89	16	\$110.24
Liquid Nails	10 oz Tube	\$2.99	24	\$71.76
Screws	Box of Drywall Screws	\$19.99	1	\$19.99

Total Cost of Supplies from Midway	Total Cost of Supplies with Tax from Midway
\$408.71	\$437.32



MIDWAY BUILDING SUPPLY, INC.
 4865 ATLANTA HWY
 ALPHARETTA, GA. 30004
 FAX (770)475-6524
 PHONE: (770) 475-7067
 www.midwaybuildingsupply.com

PAGE NO 1

RETURNS MUST BE WITHIN 30 DAYS W/RECEIPT

CUST NO:	JOB NO:	PURCHASE ORDER:	REFERENCE:	TERMS:	CLERK:	DATE / TIME:
13930	013			1% 10TH, NET 11TH	KL	10/13/14 3:39

SOLD TO:
 DAVID COX
 P O BOX 1381
 ALPHARETTA GA 30009

SHIP TO:
 BRIAN LEE JOB
 110 CHRISTOPHER RUN
 OFF OF THOMPSON RD.
 GA

TERMINAL: 565
 EXP. DATE: 10/14/14

SALESPERSON: KL KEITH LEE
 TAX: 001 FORSYTH-CHARGE

ESTIMATE: 734312

LINE	SHIPPED	ORDERED	UM	SKU	DESCRIPTION	SUGG	UNITS	PRICE/ PER	EXTENSION
1		64	PC	248S	2X4X8 #2 SPRUCE	3.42	64	3.23 /PC	206.72
2		16	PC	12WAF	7/16" 4X8 WAFER BD. OSB	7.09	16	6.89 /PC	110.24
3		24	EA	LNS	LIQUID NAILS 10oz TUBE		24	2.99 /EA	71.76
4		1	BX	5158DS	5LB 6X1-5/8" DRYWALL SCREWS		1	19.99 /BX	19.99
5					PART# 47126				
6									

TAXABLE	408.71	SUBTOTAL	408.71
NON-TAXABLE	0.00		

SUBTOTAL 408.71

TAX AMOUNT 28.61

TOTAL 437.32

TOT WT: 0.00

X _____
 Received By

Returns must be within 30 days with original receipt. Special orders are non-returnable.

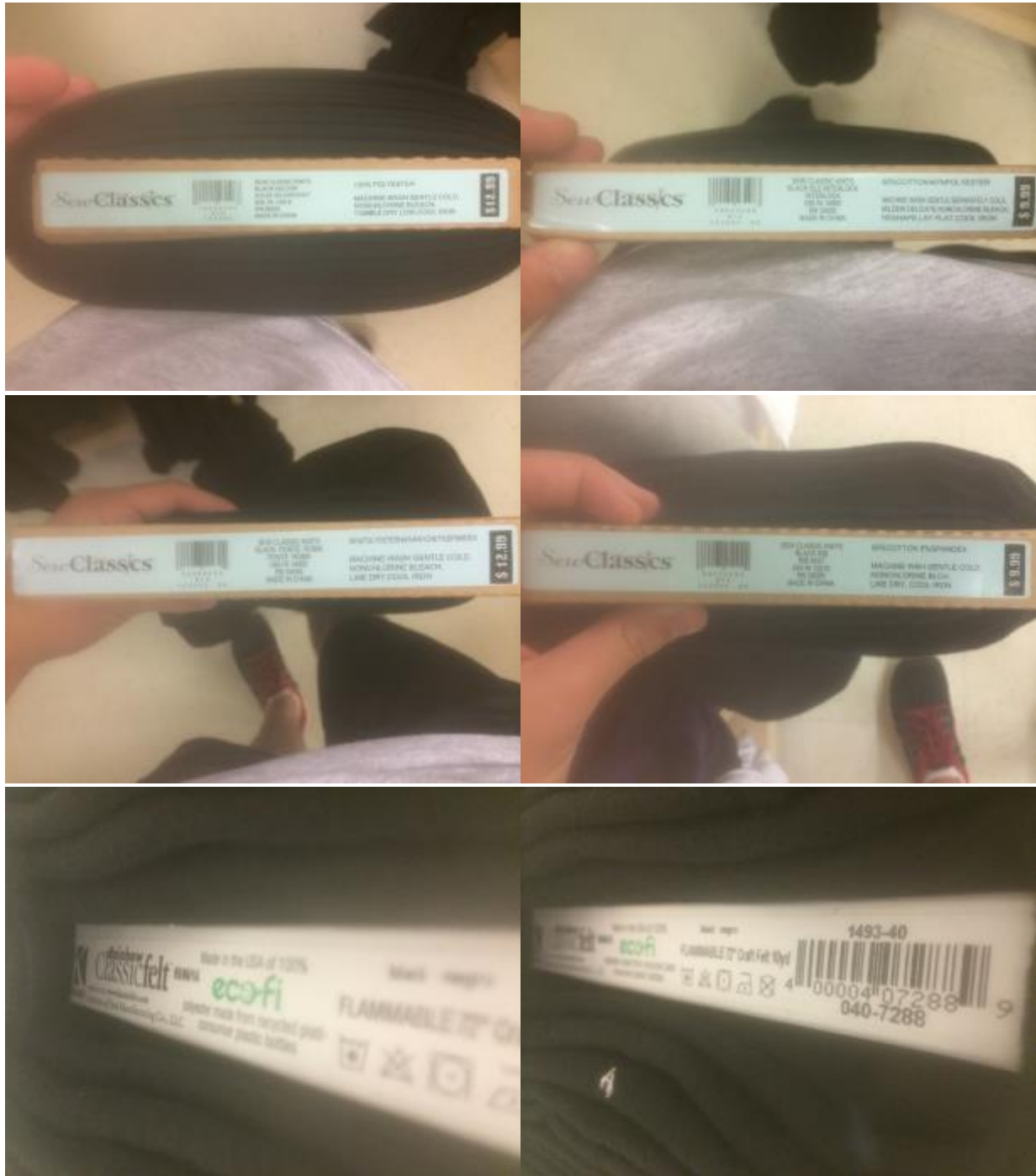

Appendix O (Joan Fabrics Price Analysis)



Appendix P (Car Wash Email Blast)

[announce] Eagle Car Wash--Need help! 



 Troop 69 Email <lstadm@miltontroop69.org>
to Betty, Announce 

8/27/14 



Dear Fellow Scouts and Friends,

My name is Tyler Lee, I am a Life Scout as well as a senior at Cambridge High School. I am going to build art displays for the Cambridge Art Department for my Eagle Scout Project.

In order to fund this project I am organizing a car wash THIS SATURDAY, August 30th from 10:00 AM until 3:00 PM at the Chick-fil-A on Windward Parkway and need your help! Please email me at tle753@gmail.com with the hours you can assist with. Any time will be appreciated and lunch will be provided to participants at noon!

Parents, please consider stopping by and supporting this cause, and leaving with a sparkling vehicle!

Thank you!

Tyler

tle753@gmail.com
(678-729-1126)

Appendix Q (Car Wash Hour Log)

YOUTH			
Name	Time In	Time Out	Hours
Tyler Lee	9:00 AM	3:30 PM	6.5
Lauren Lee	9:15 AM	3:30 PM	6.25
Brandon Lee	9:15 AM	3:30 PM	6.25
Andrew Leigh	10:00 AM	12:00 PM	2
Seth Leigh	10:00 AM	12:00 PM	2
Cole Anderson	10:20 AM	1:30 PM	3.17
Josh Gargan	11:10 AM	3:00 PM	3.83
Makund Aravapalli	11:20 AM	1:00 PM	1.67
Anish Gupta	11:20 AM	12:45 PM	1.42
Mitchell Rosnow	10:50 AM	12:30 PM	1.67
Colton Belle Isle	11:00 AM	1:00 PM	2
Jack Chasin	11:00 AM	1:00 PM	2
		Total	38.76

ADULTS			
Name	Time In	Time Out	Hours
Brian Lee	9:00 AM	3:30 PM	6.5
Lynna Lee	9:15 AM	3:30 PM	6.25
Betty Lou Anderson	10:20 AM	1:30 PM	3.17
		Total	15.92

		Grand Total	54.68
--	--	--------------------	-------

Appendix R (Donation Letter)



Dear Family/Friend,

Scouting is and will always be an integral part of my life from the drastically different experiences to the everyday skills that allow me to live a happier, more productive life. I have done everything from viewing the construction of fighter jets at Lockheed Martin to sliding down muddy chutes deep underground the Earth's surface and now I am attempting to earn Scouting's most prestigious achievement, the rank of Eagle.

My project consists of building eight to ten art displays for my high school's art department to allow students to portray their masterpieces in a professional setting. Each display will consist of two frames hinged together with a plywood board and insulation panel mounted on top. The entire surface of both sides will then be covered in a quality fabric that will resist tearing from the push-pins holding the artwork in place.

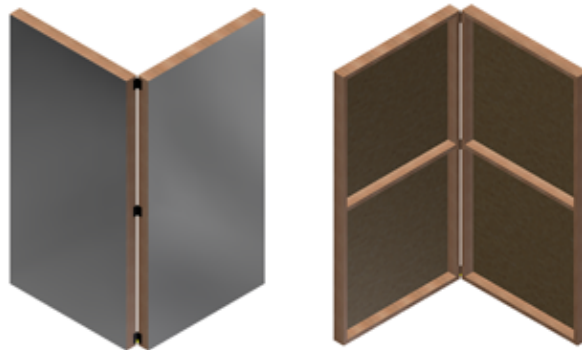

To obtain the funding required I held a car wash which, with the support of family and fellow scouts, raised nearly five hundred dollars! Yet, I am not quite at my goal of seven hundred to eight hundred dollars needed for such a substantial project. In order to make my project a reality, I am asking for the financial support of family and friends. If you are willing and able to donate I would be greatly appreciative. Any amount, even ten dollars would go far in helping me complete my Eagle Scout ranking. Checks can be made out to BSA Troop 69. Thank you in advance for your donation!

Yours in scouting,

Tyler Lee

Appendix S (Donation Log)

CONTRIBUTOR	FORM OF DONATION	AMOUNT
Chic-Fil-A Carwash	Cash	471.00
Mrs. Fowinkle (Donation Letter)	Check	10.00
Mr. and Mrs. Radman (Donation Letter)	Check	25.00
Aunt Diane and Uncle Don (Donation Letter)	Check	50.00
Grandma and Grandpa Lee (Donation Letter)	Check	50.00
Aunt Jen and Uncle Mike (Donation Letter)	Check	75.00
Mr. and Mrs. Hearn (Donation Letter)	Check	30.00
Aunt Bev and Uncle Bob (Donation Letter)	Check	50.00
Aunt Sandy and Uncle Andy (Donation Letter)	Check	80.00
Aunt Shelli (Donation Letter)	Cash	10.00
	Grand Total	851.00

Appendix T (Work Processes)

Reference Key:

Board = One OSB Panel, one polystyrene insulation panel, a 4' x 8' frame of two by fours with a two by four support piece in the middle, and a 5' x 9' piece of fabric stretched over the assembly

Display = Two Boards hinged together with 8 tacks on the bottom (four per board) (final product)

1) (Site Preparations) The first step is creating a suitable work site for woodworking operations which entails removing all potential obstacles from the garage floor and ensuring there are no potential hazards for construction. All tools and supplies needed should be placed appropriately in the work space along with proper safety equipment.

2) (Cutting Wood) The second step is cutting the wood with a miter saw to the correct dimensions which must be done by a qualified adult although dimensioning help can be provided by scout.

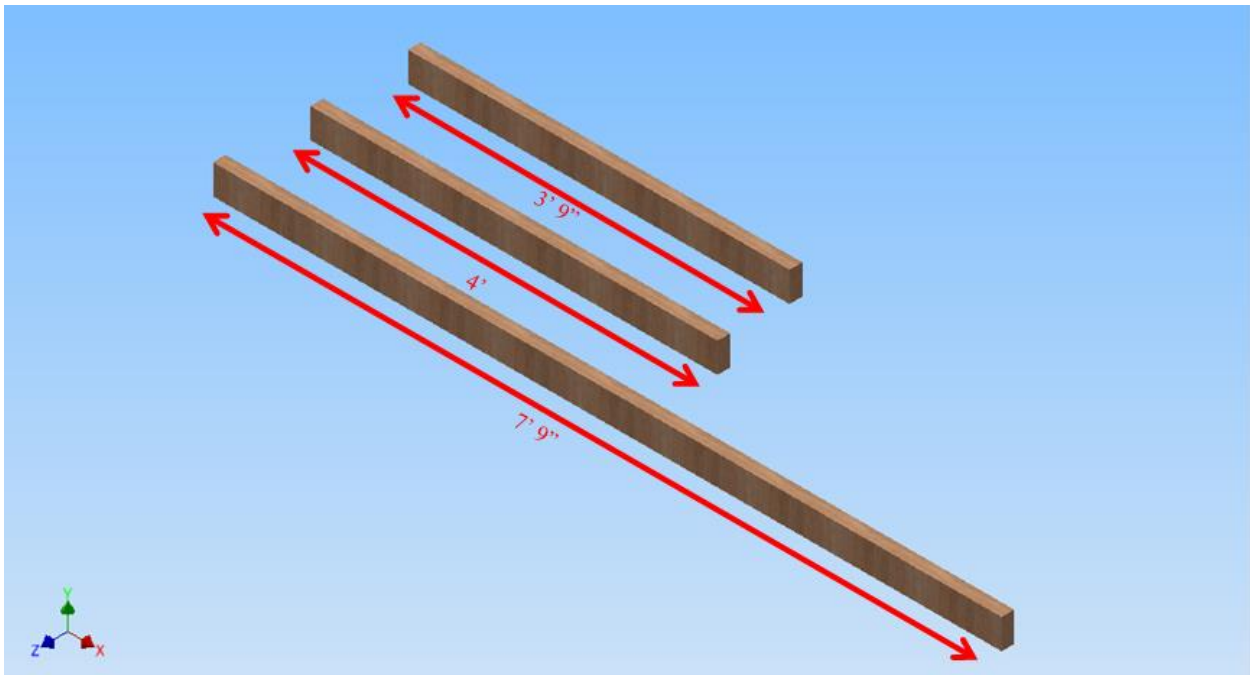

3) (Nail Wood) After aligning two 93" studs parallel to one another, lay a 48" stud on both ends and a 45" stud in the center (48" from either end) atop the level surface of the garage floor and nail the structure together with the help of workers standing atop the pieces to remove any movement and misalignment from hammering.

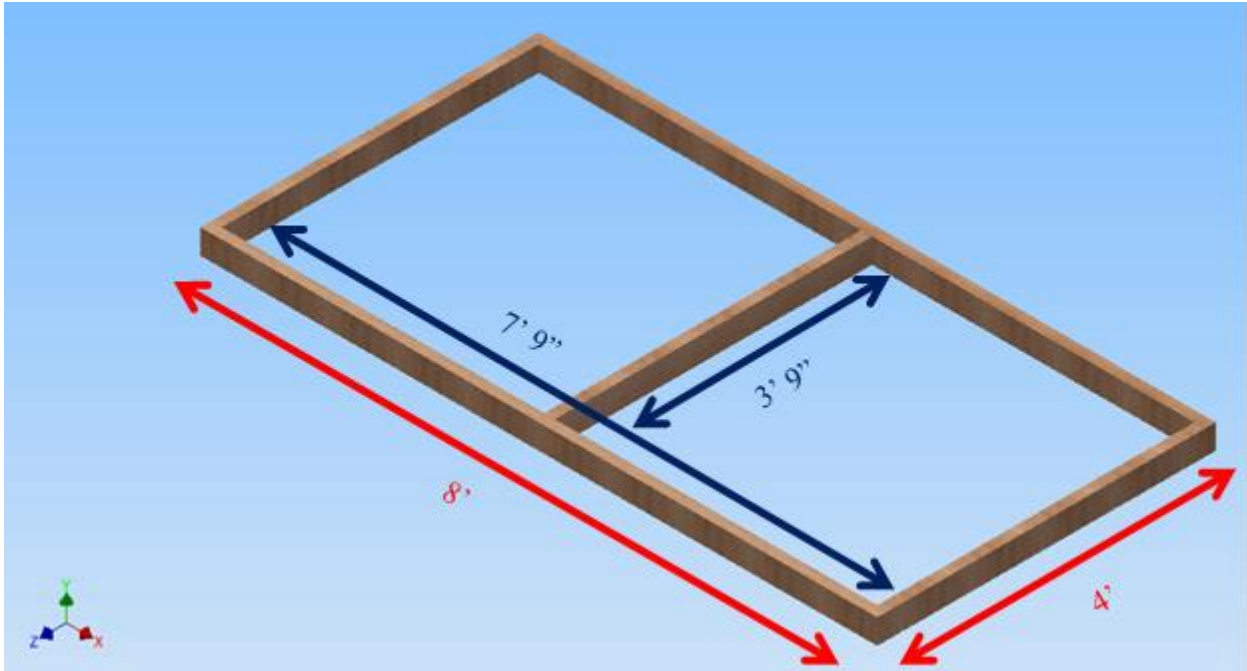

3) (OSB Panel) The frame wood is then laid out on the flat concrete to ensure proper alignment and screwed together using power drills. The OSB panel is then placed over the frame and screwed in once properly aligned. (Fits perfectly over the frame 4' x 8'.)

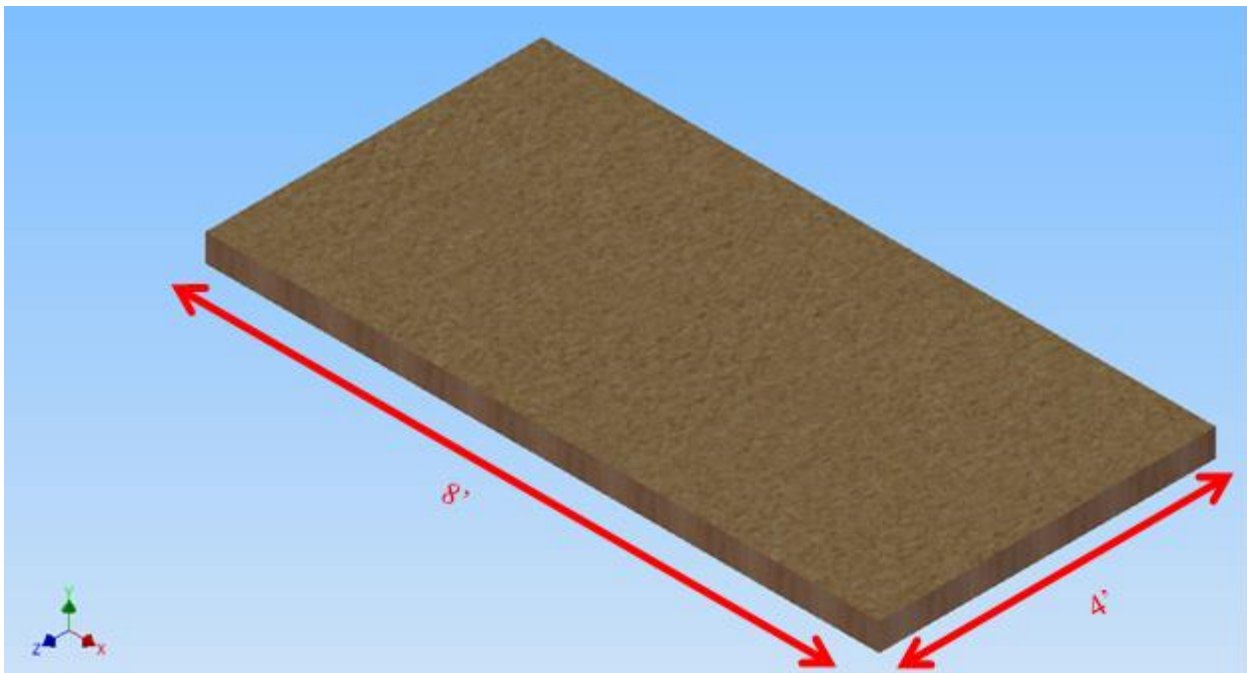

4) (Styrofoam) The next step is to use liquid nails to glue the polystyrene insulation panels over the OSB panel in an X pattern to maximize surface contact. Upon completion of gluing each display, stack the displays in stacks of 4 in an alternating fashion (insulation board sides facing

each other) to ensure pressure is applied to glue. The glue must be allowed to dry for at least 24 hours.

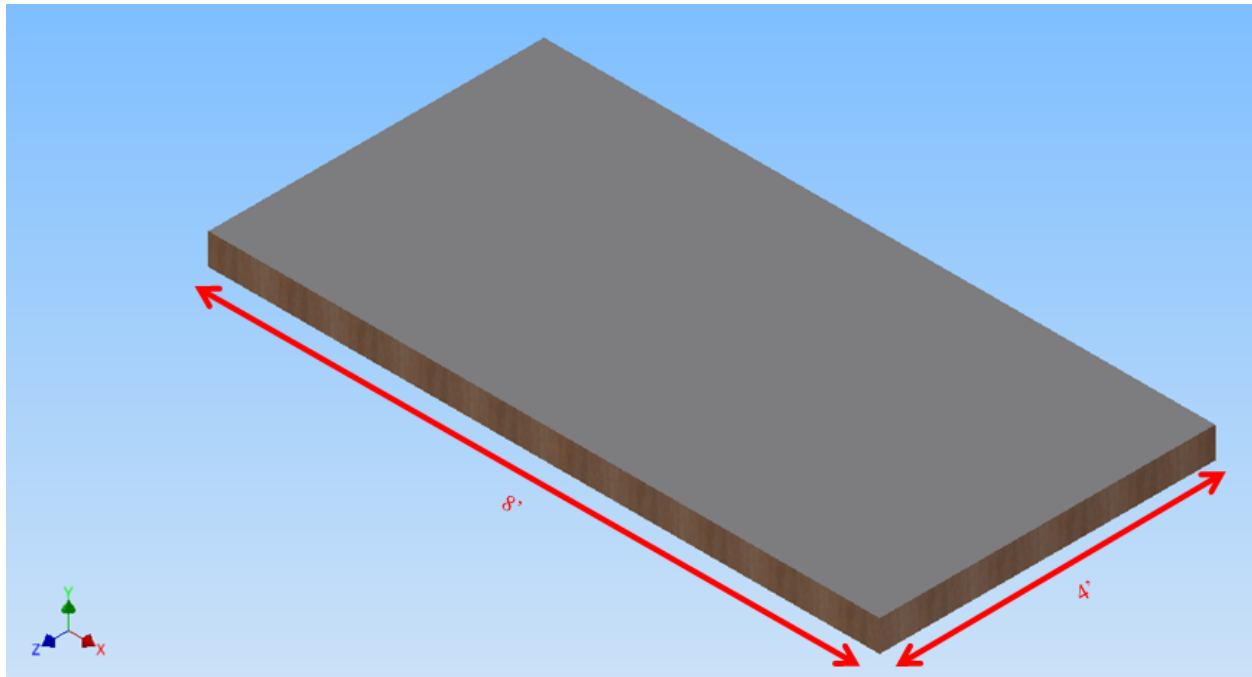

5) (Fabric Sides) The fabric is cut into 5 foot x 9 foot rectangles, ironed out, and laid atop a blanket on the garage floor. The polystyrene insulation board side of the displays is then placed atop the fabric and centered using a measuring tape to ensure the proper dimensions are in place. The staple gun at this point should be prepared for use to staple one of the long sides of the fabric to the back of the framing, leaving space at the corners to pull slack out later. (It does not need to be kept taught for this step.) Holding the fabric against the wood framing on the opposing long side of the frame, flip the display up 90 degrees and pull the fabric taught along the unstapled long side and begin stapling from the center outward, again leaving space at the corners. Still maintaining the 90 degree angle with the garage floor, the short sides of the display can be pulled taught and stapled, beginning in the center and working outward toward the corners without actually stapling the corners.

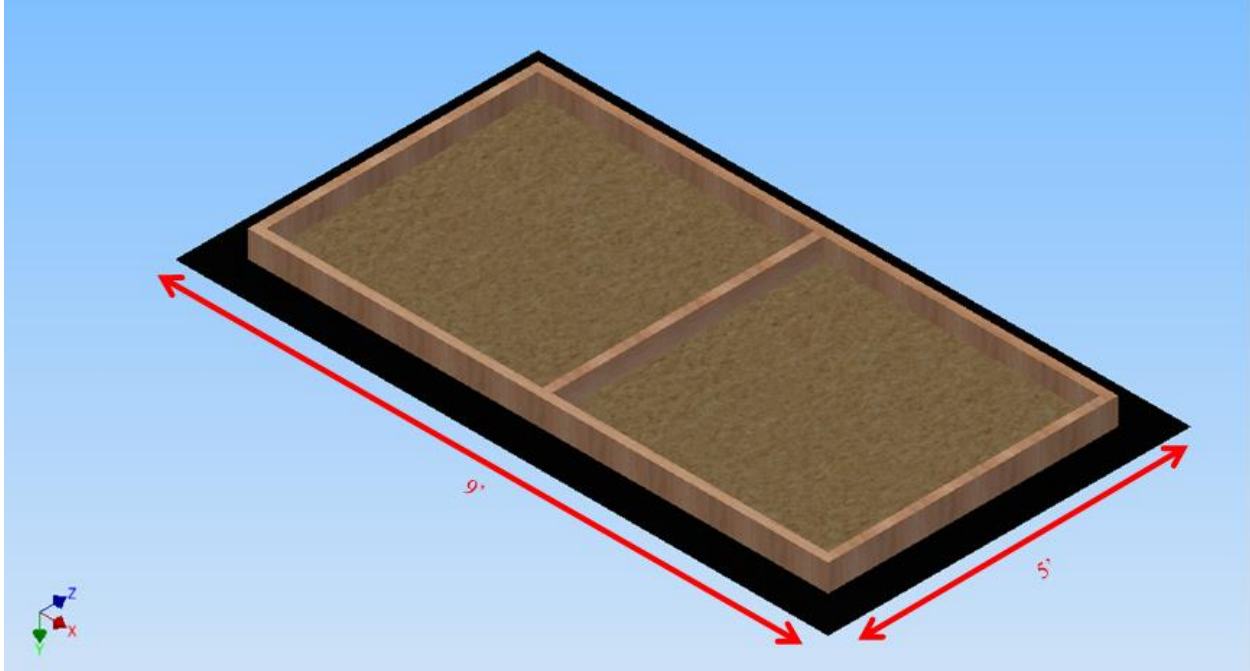

6) (Fabric Corners) While keeping the display at a 90 degree angle with the floor (for ease of access), pull the two corners taught by pulling away from the display as much as possible to ensure both sides are under maximum tension and then staple the fabric to the frame on the back side working toward the corner from both sides. After each corner has been stapled taught, take the extra fabric on the corner and fold it into a triangle (hospital corners) and staple it onto the backside framing. Once the accessible corners have been stapled, flip the display 180 degrees and repeat the corner process with the remaining two corners. Stack the boards upright to against a wall to conserve space upon completion.

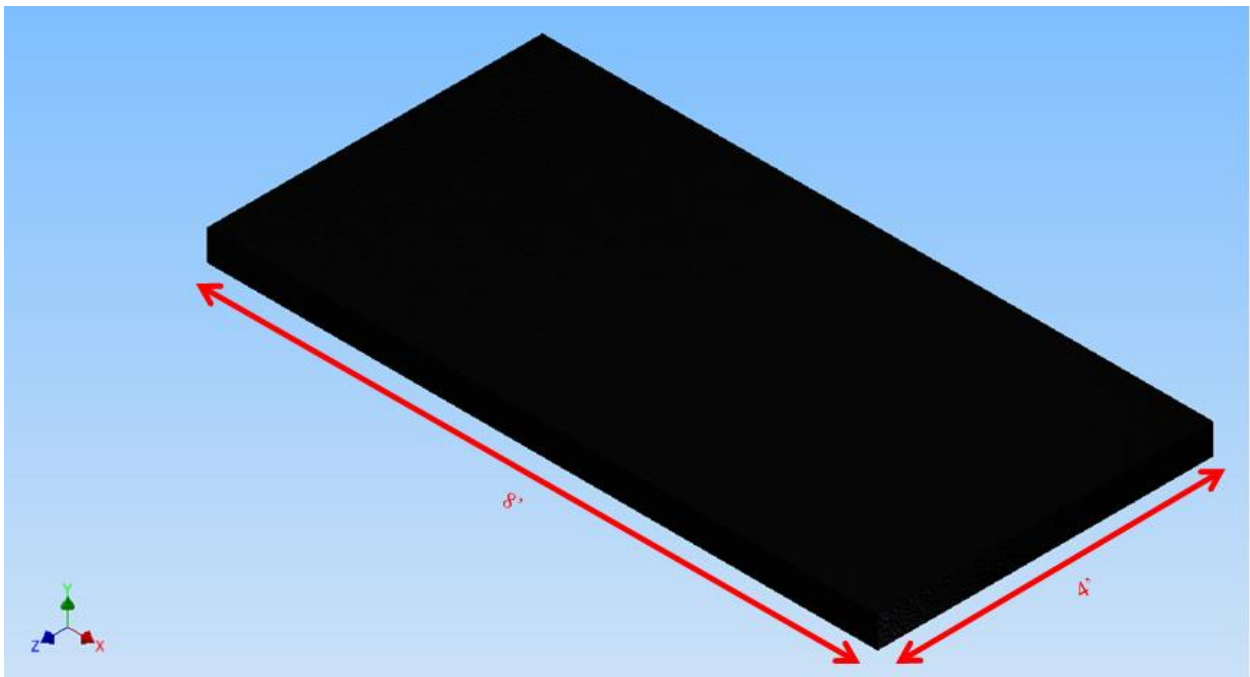
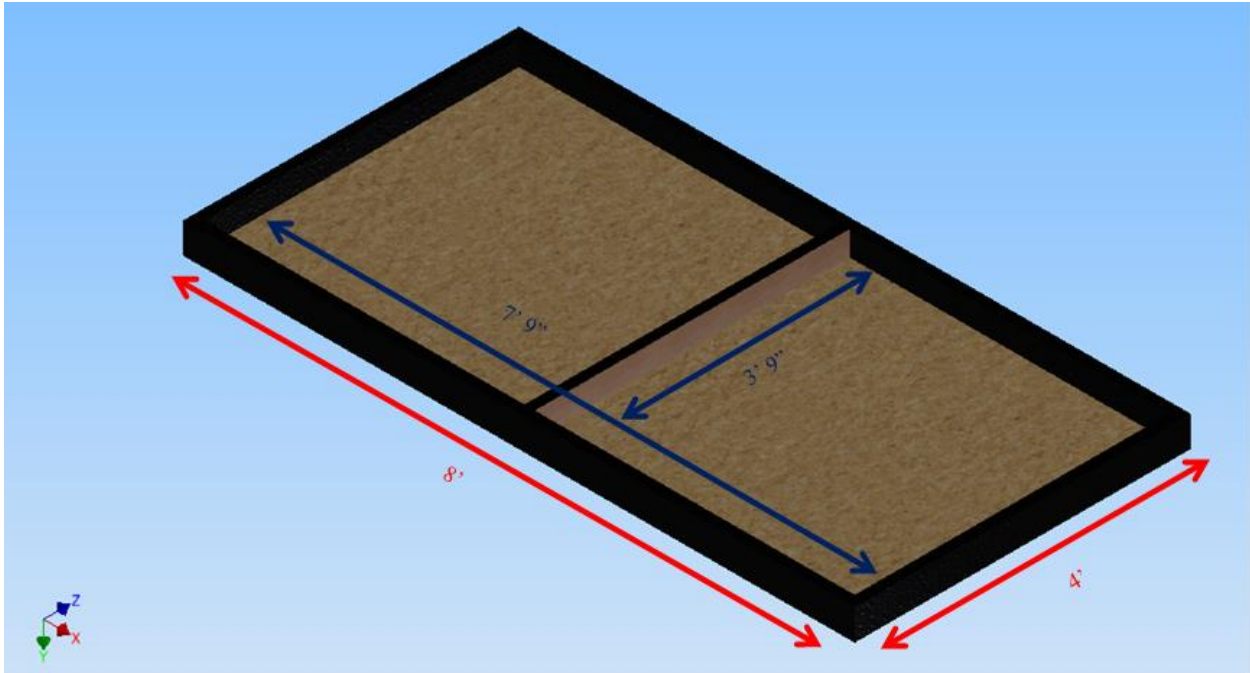

7) (Hinges) A single display should be placed insulation board side down against the blanketed garage floor, and a second display should then be placed a top this display facing the opposite direction so that the backside or frames touch. Insert several half inch pieces of scrap wood between a long side of each board to ensure proper spacing for hinges. A pair of hinges can then be spaced 6 inches from each end and another pair spaced 32 inches from each end. Before screwing, ensure that all the pins on the hinges are facing the same direction, and use provided hinge screws to screw boards together into display.

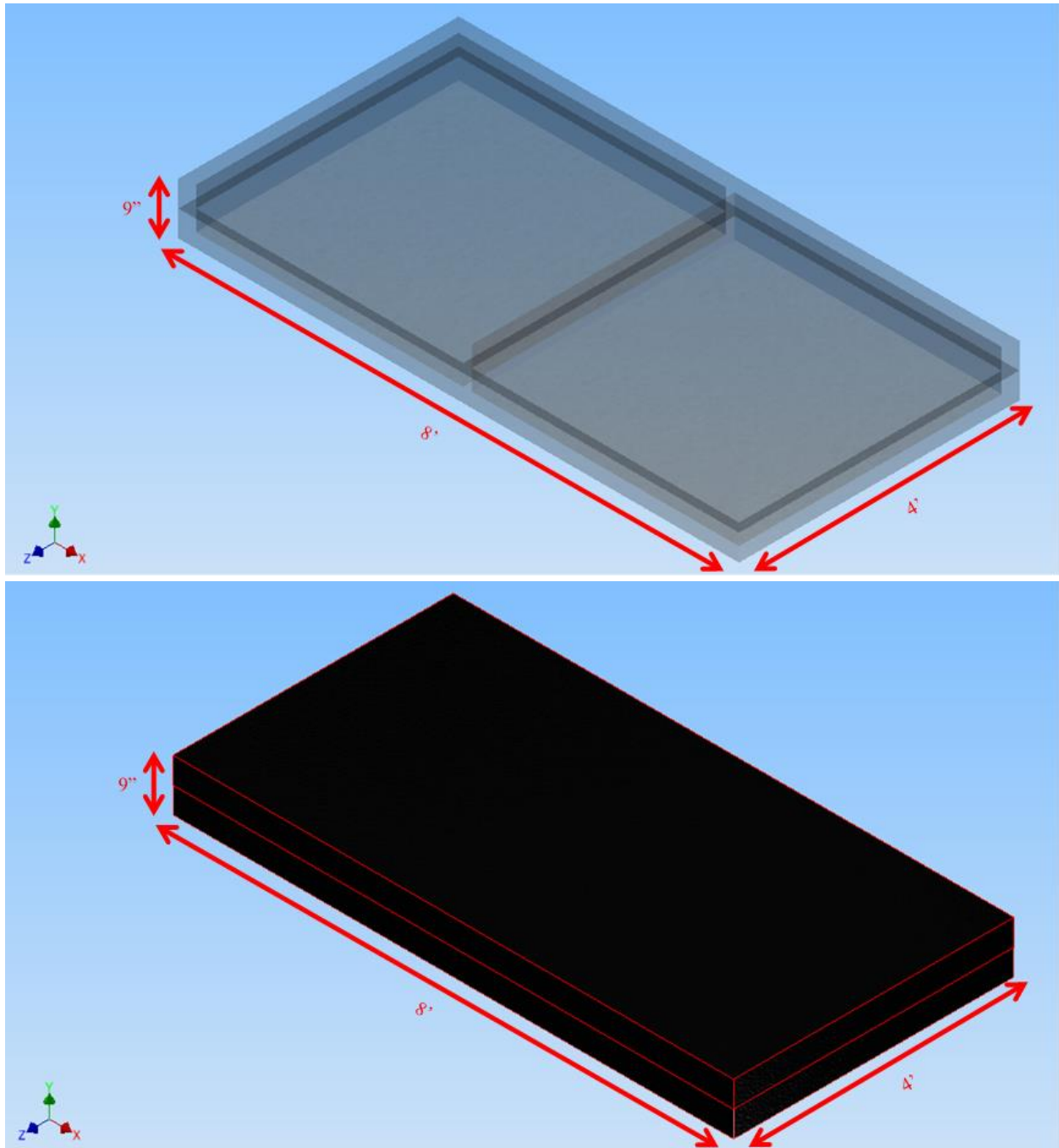

8) (Tacks) Using a scrap piece of cardboard (or other similarly flat material) create a jig for hammering 8 tacks into the bottom of the displays by cutting out a 4 1/2" x 4" rectangle. Then cut small holes into the cardboard 1 1/2" from the long side of the cardboard and 1 inch from one of the short sides as well as 2 inches from the other short side. (Ensures the tacks are not nailed into plywood or insulation panels.) Align the jig along the bottom (opposite side the hinge pins face) and hammer the tacks in halfway before removing the jig and hammering the tacks in all the way. Flip the jig and repeat for each side of the board as well as repeating for the other board. (attached by hinges to create one display)

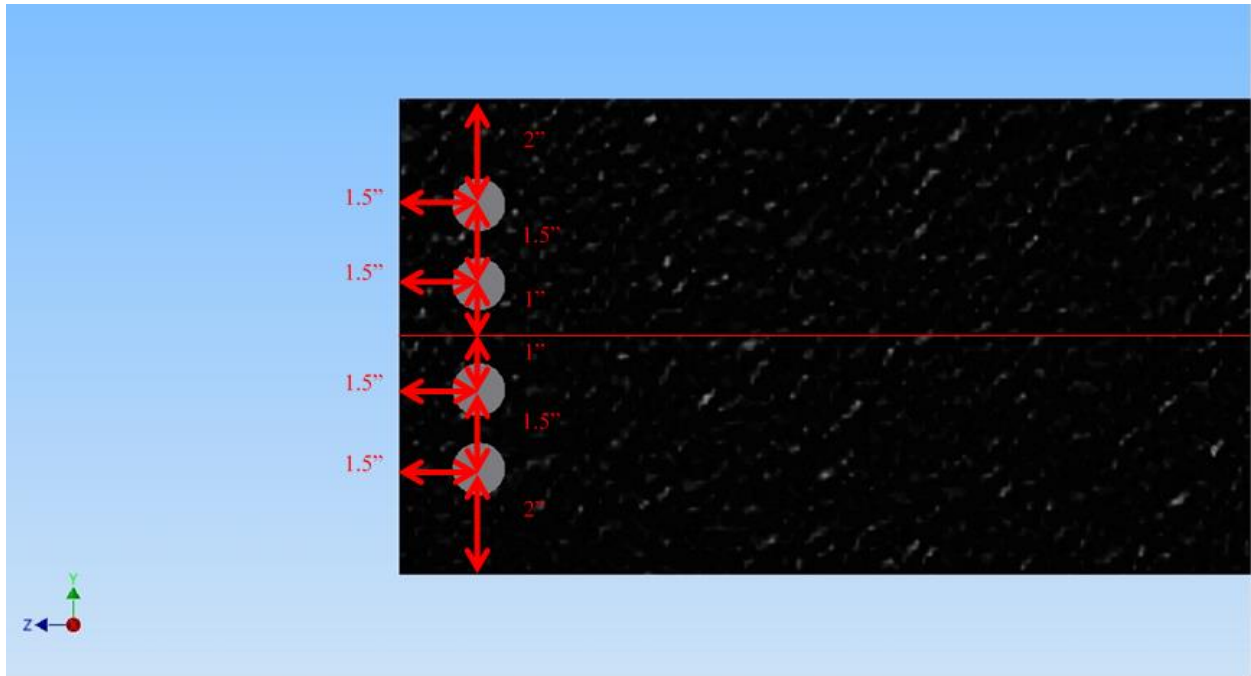

9) (Clean Up) Unplug all power tools, and return tools and supplies to owners, sweep the garage floor, and throw away all waste packaging. Leftover materials should be given to beneficiary for use at their discretion.

Appendix U (Art Display Hour Log)

YOUTH				
Name	Date	Time In	Time Out	Hours
Tyler Lee	11/26/14	10:00	6:00	8
Chris Moneyron	11/26/14	11:30	4:00	4.5
Lauren Lee	11/26/14	12:00	4:00	4
Brandon Lee	11/26/14	12:00	3:30	3.5
Jason Hink	11/26/14	12:00	4:00	4
Tyler Lee	11/28/14	5:00	9:00	4
Tyler Lee	12/6/14	10:00	5:30	7.5
Luke Martin	12/6/14	10:15	5:30	7.25
Rachel Lee	12/6/14	12:00	3:00	3
Brandon Lee	12/6/14	11:00	3:00	4
Tyler Lee	12/20/14	2:00	8:00	6
Luke Martin	12/20/14	2:00	6:00	4
John Barnabei	12/20/14	5:00	8:00	3
			Total	62.75

ADULTS				
Name	Date	Time In	Time Out	Hours
Brian Lee	11/26/14	11:00	5:00	6
Lynna Lee	11/26/14	3:00	5:00	2
Brian Lee	11/28/14	5:00	9:00	4
Lynna Lee	12/6/14	2:00	4:00	2
Brian Lee	12/6/14	11:00	5:30	6.5
Brian Lee	12/20/14	2:00	8:00	6
			Total	26.5

			Grand Total	89.25
--	--	--	--------------------	-------

Appendix V (Personal Hour Log)

Date	Activity	Hours
3/10/14	Appendices/Workbook Creation	2
3/11/14	Appendices Editing	1
3/17/14	Appendices Editing	1
3/25/14	Workbook Editing	1
4/11/14	Appendices Editing	1
5/3/14	Google Sketches Mock Up	2.5
5/4/14	Google Sketches Editing	1.5
5/6/14	Workbook Editing	2
5/24/14	Workbook Editing	2
5/27/14	Meeting with Amy Price	1
6/6/14	Workbook Editing	1.5
6/8/14	Online Fabric Research/Edit	4
6/9/14	Home Depot/Lowes Research	5.5
6/11/14	Online Fabric Research	1
6/12/14	Fabric Research	3
7/10/14	Autodesk Display Mockup	3
7/11/14	Autodesk Sketches	2.5
7/12/14	Meet with Eagle Coach	0.5
7/21/14	Workbook Editing	1
8/18/14	Car Wash Announcement	1
8/24/14	Poster Making	1.5
8/25/14	Car Wash Preparation	2
8/27/14	Car Wash Organization	1
8/29/14	Car Wash Preparation	1
8/30/14	Car Wash Fundraiser	8
9/2/14	Donation Letter Work	3

9/3/14	Donation Letter Mailing	1.5
9/30/14	Donation Letter Recording	1.5
10/12/14	Materials Planning	2
10/13/14	Materials Cost Analysis	4
10/25/14	Home Depot Quote/Pickup	4
11/8/14	Joan Fabric Quote/Pickup	3
11/10/14	Joan Fabric Pickup	0.5
11/13/14	Costco Gift Basket Purchase	0.25
11/22/14	Cutting Wood	3
11/25/14	Workday Preparation	1.5
11/26/14	Framework Workday	8
11/28/14	Gluing Insulation Foam	4
11/29/14	Buying Supplies	2.5
12/5/14	Fabric Preparation	1.5
12/6/14	Fabric Workday	7.5
12/20/14	Final Workday	6
12/21/14	Worksite Clean Up	1.5
1/06/15	Moving Displays	3
1/21/15	Workbook Editing	1
1/22/15	Appendices Editing	1
1/23/15	Workbook Editing	2
1/26/15	Workbook Editing	1
2/2/15	Workbook Editing	1
2/11/15	Appendices Editing	2
2/23/15	Meet with Eagle Coach	1
2/24/15	Appendices Editing	1
2/25/15	Application Editing	0.25
2/27/15	Appendices Editing	2
3/1/15	Appendices Editing	2.5

3/9/15	Appendices Editing	1
3/13/15	Workbook Editing	1.5
3/15/15	Workbook Editing	0.5
3/16/15	Workbook Editing	1
3/17/15	Appendices Editing	2
	Total	130.5

Appendix W (Final Autodesk Renderings)



Front

Side

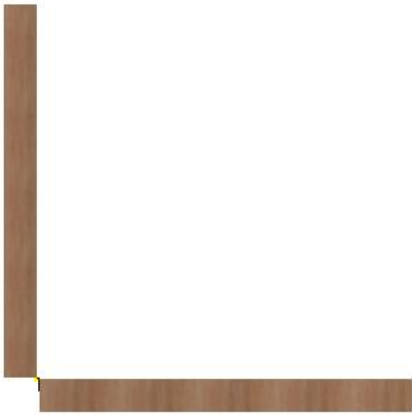

Top

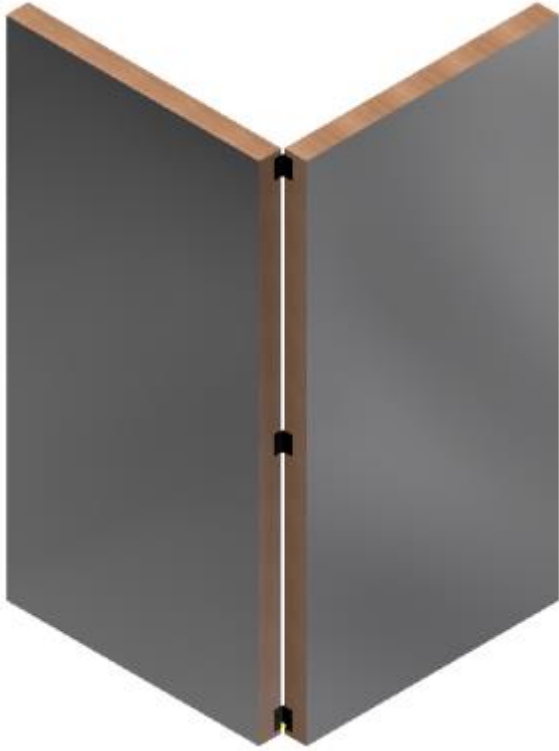

Front Isometric



Back Isometric

Appendix X (Art Display Photos)





Appendix Y (Check to Beneficiary)

BOY SCOUT TROOP NO. 69
TREASURER
3075 GREENS CREEK LANE
ALPHARETTA, GA 30009

2015
64-137/611

3/24/15 DATE

CHECK NUMBER

PAY TO THE ORDER OF Cambridge High School \$ 20.58

Twenty and 58/100 DOLLARS

Security Features Details on Back

 **REGIONS**

FOR Apt Dept. Neil Blom

⑆061101375⑆ 6410719544⑆02015

Harland Clarke